



**THANK YOU FOR YOUR PURCHASE!**

FOR ANY QUESTIONS PLEASE REACH OUT TO:

[info@cfmotousaparts.com](mailto:info@cfmotousaparts.com)

(845) 5-CFMOTO

(845) 523-6686

9AM-5PM EST Mon-Fri

**OUR FRIENDLY STAFF IS READY TO ASSIST YOU**

## ACCESSORY SETUP INSTRUCTION

### REAR NERF BARS ASSY -- PN 9DQV-802300-3000

VALID FOR: CFORCE 400 & 400 TOURING

**BEFORE YOU BEGIN:** Read and understand the instructions before starting any work. Make sure that all parts are ready and that you have all the tools required for assembly.

**NOTE:** CFMOTO shall not be liable for any damage caused by incorrect assembly. CFMOTO recommends that all original accessories be assembled by an authorized CFMOTO dealer.

Before assembly, park the vehicle on a flat surface, put the transmission gear into Park (P) and turn off the key switch.

**Zhejiang CFMOTO Power Co., Ltd.** All rights reserved. Reproduction of this document, even in part, as well as copying of all kinds, is permitted only with the express written permission of the copyright owner.

### MEANING OF SYMBOLS

 - Indicates information with more details or tips.

 - Indicates information of warning or danger.

### PARTS LIST:

ITEM	PART NAME	PART NUMBER	QTY.	REMARK
1	REAR NERF BARS ASSY	9DQV-802300-3000	1	Picture is for structure reference only.
2	MIDDLE NERF BARS ASSY	9DQV-802210-3000	1	
3	LH NERF BARS ASSY	9DQV-802320-3000	1	
4	RH NERF BARS ASSY	9DQV-802330-3000	2	
5	SCREW M6×20	9DQV-802300-3000-20	6	
6	SELF LOCK NUT M6	9DQV-802300-3000-21	6	

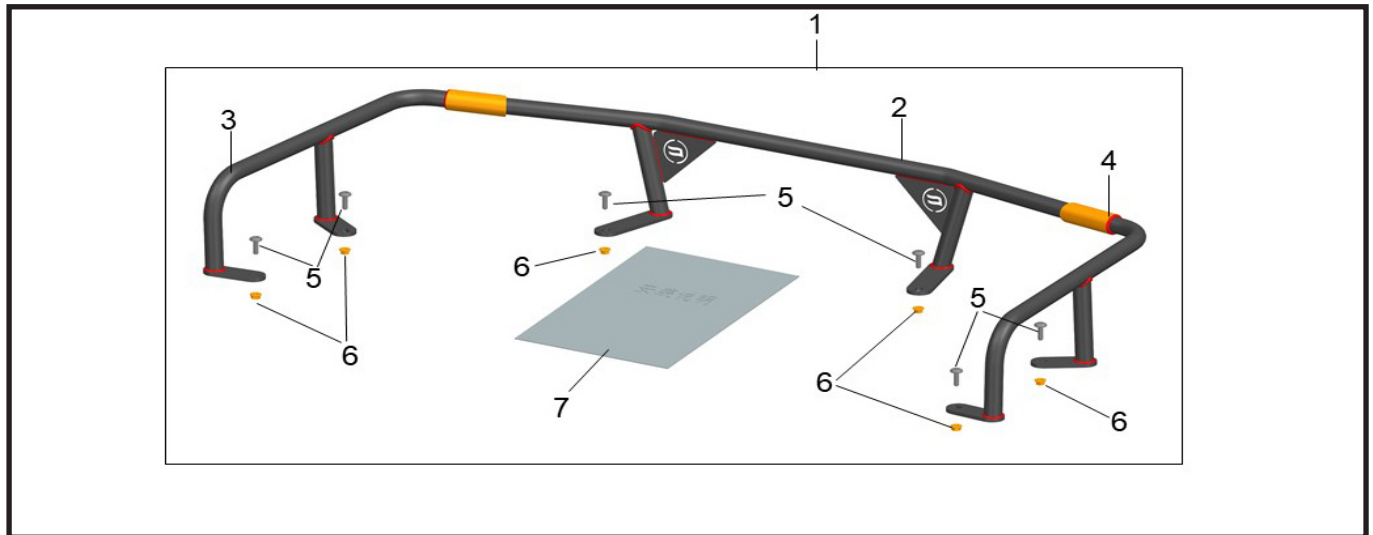

### TOOL LIST:

ITEM	DESCRIPTION	QTY.	REMARK
1	PROTECTIVE GLOVES	1	Recommended tools.
2	10mm OPEN END WRENCH	1	
3	5mm ALLEN WRENCH	1	

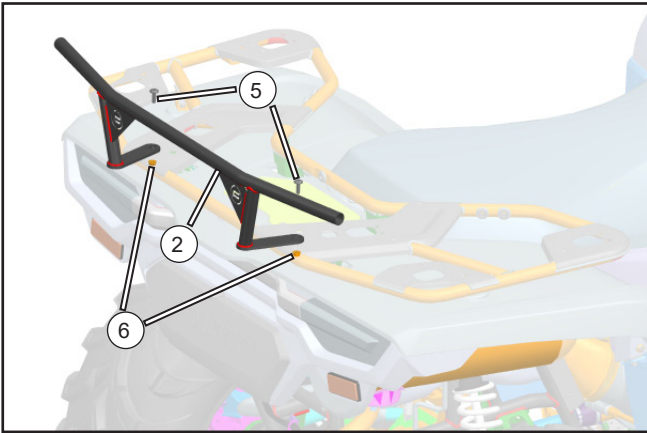
**ASSEMBLY and INSTALLATION**

// Install the middle nerf bars (2) with screws (5) and self lock nuts (6). Do not fully tighten at this time.

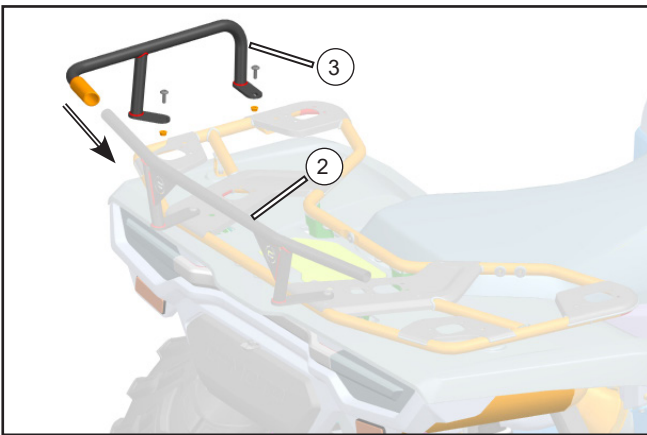

// As shown in the picture, connect the left nerf bars (3) with the middle nerf bars (2).

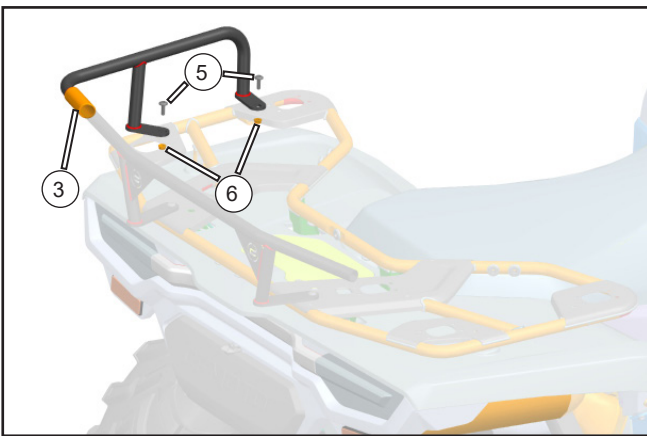

// Secure the left nerf bars (3) with screws (5) and self lock nuts (6). Do not fully tighten at this time.

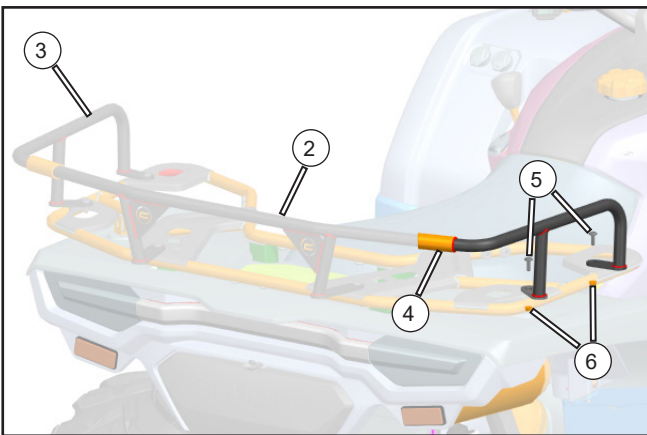

// As shown in the picture, connect the right nerf bars (4) with the middle nerf bars (2).

// Secure the right nerf bars (4) with screws (5) and self lock nuts (6). Do not fully tighten at this time.

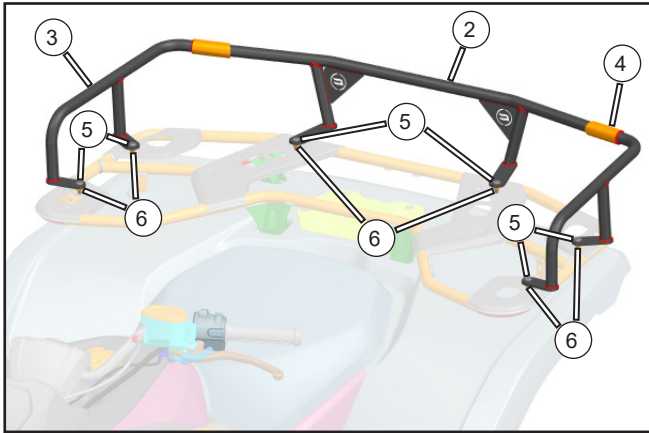
**ASSEMBLY and INSTALLATION**

// Tighten all screws (5) and self lock nuts (6) with Allen wrench and open-ended wrench.

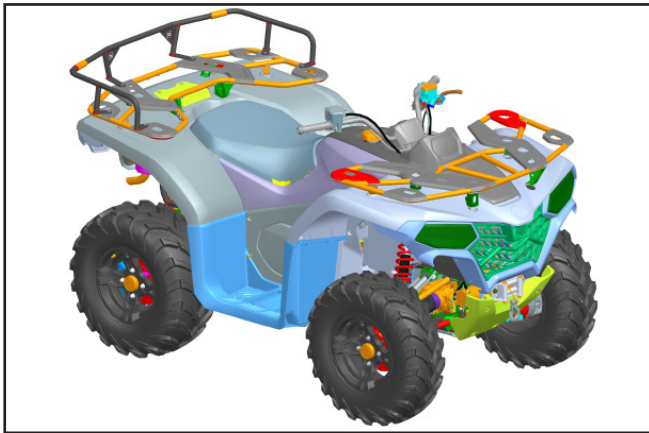

// The rear nerf bars are assembled.